

# Drive Couplings

## Technical Data



### Materials

**Coupling halves**  
Sintered Steel

**Sleeve**  
Nylon 66

**Max temp sleeve**  
83°C

To select coupling model check application to establish running load condition.

Check chart for factor (F) and apply factor (F) to \*Rating of coupling formulae. This answer you now apply to \*Rating/100 rev/min below.

It is advisable always to check shaft sizes being used on application and check with dimension 'H'.

Application	Factor (F)	
	Electric motor	Petrol/diesel engine
Uniform load	1.00	1.20
Medium shock	1.25	1.50
Heavy shock	1.75	2.00

$$\text{*Rating of coupling} = \frac{\text{HP of application} \times 100 \times F}{\text{rev/min of application}}$$

## Installation Details

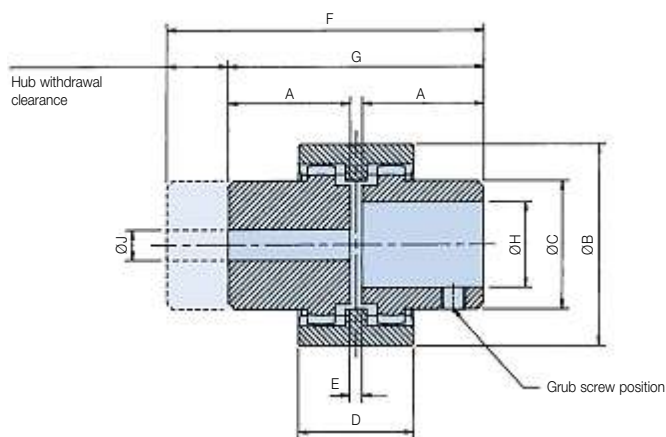

### Sectioned detail

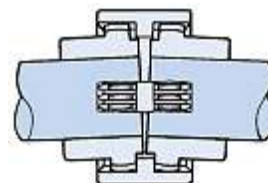

Part number prefix	Max speed rev/min	*Rating/100 rev/min		Weight	A mm	B mm	C mm	D mm	E mm	F mm	G mm	max bore	H-min bore	J pilot bore
DC28*	5000	0.75	1.00	0.4	40.0	66.0	44.5	38.0	4.0	104.0	84.0	28.0	10.0	7.0
DC42*	5000	1.32	1.75	0.75	42.0	90.0	60.0	42.0	4.0	115.0	88.0	42.0	14.0	10.5
DC55*	4000	6.00	8.00	2.05	59.0	125.0	83.0	65.0	4.0	158.0	122.0	55.0	19.0	16.0 min 38.1 max

### Height of keyway from base of bore

	Metric	Imperial
Standard bore	BS 4500, (1985)	BS 1916, Part 1, (1985)
Standard keyway	BS 4325, Part 1 (1980)	BS 46, Part 1, (1985)

### Assembly data

1. Maximum angular misalignment is  $\pm 2^\circ$ . Maximum radial misalignment is  $\pm 0.4$ mm.
2. Ensure that the Parker Filtration drive coupling gear hubs are an easy fit to their respective shafts. Do not use heavy blows to force the hubs on.
3. When in position, the hubs should have a gap of 4mm as denoted by 'E' dimension.
4. Tighten grub screws to locate both gear hubs on to their respective shafts.

## Ordering Examples

Parker Filtration drive coupling components are ordered separately. Here are three examples of complete assemblies ordered this way.

1. Complete assembly – **DC28M14B04K**  
Made up of a **DC28M14**  
**DC28B04K**  
**DC28.S** (Sleeve)

Complete model **DC28** drive coupling: One gear hub has 14mm bore with 5mm wide keyway and other hub has a 1/2" bore with 0.125" wide keyway.

Both hubs supplied with locating grub screw.

2. Complete assembly – **DCR42PBPB**  
Made up of 2x **DCR42PB's**  
**DC42S** (Sleeve)

Complete model **DC42** drive coupling: Both gear hubs have pilot bore of 10.5mm. Not supplied with grub screws.

3. Complete assembly – **DCR55PBB12K**  
Made up of a **DCR55PB**  
**DC55B12K**  
**DC55S** (Sleeve)

Complete model **DC55** drive coupling: One gear hub pilot bored 5/8", the other hub pilot bored 1 1/2". Latter only supplied with grub screw.

# Drive Couplings

## Ordering Information

### Model DC.28

Part number	Supersedes	Dimensions (mm)			Weight
		Ø Bore	Width	Height	
<b>DC28M16</b>	DC.28.M16	16.0mm	5.0mm	18.4mm	Range from 0.259Kg to 0.411Kg
<b>DC28M19</b>	DC.28.M19	19.0mm	6.0mm	21.9mm	
<b>DC28M20</b>	DC.28.M20	20.0mm	6.0mm	22.9mm	
<b>DC28M22</b>	DC.28.M22	22.0mm	6.0mm	24.9mm	
<b>DC28M24</b>	DC.28.M24	24.0mm	8.0mm	27.5mm	
<b>DC28M25</b>	DC.28.M25	25.0mm	8.0mm	28.5mm	
<b>DC28M28</b>	DC.28.M28	28.0mm	8.0mm	31.5mm	
<b>DCR28PB</b>	DCR.28.PB	N/A	8.0mm	N/A	
<b>DC28S</b>	DC.28.S	N/A	N/A	N/A	
<b>DC28M10</b>	DC.28.M10	10.0mm	3.0mm	11.5mm	
<b>DC28M11</b>	DC.28.M11	11.0mm	4.0mm	12.9mm	
<b>DC28M14</b>	DC.28.M14	14.0mm	5.0mm	16.4mm	
<b>DC28M18</b>	DC.28.M18	18.0mm	6.0mm	20.9mm	
DC28B03K	DC.28.B03K	7/16	0.125 ins	0.50 ins	
DC28B04K	DC.28.B04K	1/2	0.125 ins	0.57 ins	
DC28B05K	DC.28.B05K	5/8	0.188 ins	0.72 ins	
DC28B06K	DC.28.B06K	3/4	0.188 ins	0.84 ins	
DC28B07K	DC.28.B07K	7/8	0.250 ins	0.99 ins	
DC28B08K	DC.28.B08K	1	0.250 ins	1.12 ins	
DC28B09K	DC.28.B09K	1 1/8	0.313 ins	1.24 ins	

### Model DC.42

Part number	Supersedes	Dimensions (mm)			Weight
		Ø Bore	Width	Height	
<b>DC42M25</b>	DC.42.M25	25.0mm	8.0mm	28.5mm	Range from 0.436Kg to 0.753Kg
<b>DC42M28</b>	DC.42.M28	28.0mm	8.0mm	31.5mm	
<b>DC42M30</b>	DC.42.M30	30.0mm	8.0mm	33.5mm	
<b>DC42M35</b>	DC.42.M35	35.0mm	10.0mm	38.5mm	
<b>DC42M38</b>	DC.42.M38	38.0mm	10.0mm	41.5mm	
<b>DC42M42</b>	DC.42.M42	42.0mm	12.0mm	45.5mm	
<b>DCR42PB</b>	DCR.42.PB	N/A	12.0mm	N/A	
<b>DC42S</b>	DC.42.S	N/A	N/A	N/A	
<b>DC42M18</b>	DC.42.M18	18.0mm	6.0mm	20.9mm	
<b>DC42M19</b>	DC.42.M19	19.0mm	6.0mm	21.9mm	
<b>DC42M20</b>	DC.42.M20	20.0mm	6.0mm	22.9mm	
<b>DC42M22</b>	DC.42.M22	22.0mm	6.0mm	24.9mm	
<b>DC42M24</b>	DC.42.M24	24.0mm	8.0mm	27.5mm	
<b>DC42M32</b>	DC.42.M32	32.0mm	10.0mm	35.5mm	
DC42B05K	DC.42.B05K	5/8	0.188 ins	0.72 ins	
DC42B06K	DC.42.B06K	3/4	0.188 ins	0.84 ins	
DC42B07K	DC.42.B07K	7/8	0.250 ins	0.99 ins	
DC42B08K	DC.42.B08K	1	0.250 ins	1.12 ins	
DC42B09K	DC.42.B09K	1 1/8	0.313 ins	1.24 ins	
DC42B10K	DC.42.B10K	1 1/4	0.313 ins	1.37 ins	
DC42B11K	DC.42.B11K	1 3/8	0.375 ins	1.49 ins	
DC42B12K	DC.42.B12K	1 1/2	0.375 ins	1.61 ins	
DC42B13K	DC.42.B13K	1 5/8	0.439 ins	1.76 ins	

### Model DC.55

Part number	Supersedes	Dimensions (mm)			Weight
		Ø Bore	Width	Height	
<b>DCR55PB</b>	DCR.55.PB	N/A	16.0mm	N/A	Range from 1.248 Kg – 2.046 Kg
<b>DC55S</b>	DC.55.S	N/A	N/A	N/A	
DC55M25	DC.55.M25	25.0mm	8.0mm	28.5mm	
DC55M28	DC.55.M28	28.0mm	8.0mm	33.5mm	
DC55M30	DC.55.M30	30.0mm	8.0mm	33.5mm	
DC55M32	DC.55.M32	32.0mm	10.0mm	35.5mm	
DC55M35	DC.55.M35	35.0mm	10.0mm	38.5mm	
DC55M38	DC.55.M38	38.0mm	10.0mm	41.5mm	
DC55M42	DC.55.M42	42.0mm	12.0mm	45.5mm	
DC55M55	DC.55.M55	55.0mm	16.0mm	59.5mm	
DC55B09K	DC.55.B09K	1 1/8	0.313 ins	1.24 ins	
DC55B10K	DC.55.B10K	1 1/4	0.313 ins	1.37 ins	
DC55B11K	DC.55.B11K	1 3/8	0.375 ins	1.49 ins	
DC55B12K	DC.55.B12K	1 1/2	0.375 ins	1.61 ins	
DC55B13K	DC.55.B13K	1 5/8	0.439 ins	1.76 ins	
DC55B14K	DC.55.B14K	1 3/4	0.439 ins	1.89 ins	
DC55B15K	DC.55.B15K	1 7/8	0.501 ins	2.01 ins	
DC55B16K	DC.55.B16K	2	0.501 ins	2.13 ins	
DC55B17K	DC.55.B17K	2 1/8	0.626 ins	2.31 ins	

Note 1: Part numbers featured with bold highlighted codes will ensure a 'standard' product selection.

Note 2: Alternate displayed part number selection will require you to contact Parker Filtration for availability.